



Preliminary – Do Not Use for Construction



SPOT Travel Time Savings Report

SR 1738 (Bridges Street) from Friendly Rd to 20th Street
25 - Improve Multiple Intersections along Corridor

STIP No. - SPOT ID: H250723 WBS No. 34263.1.1 Carteret DIVISION: 2
 2/19/2026 Three Oaks Engineering

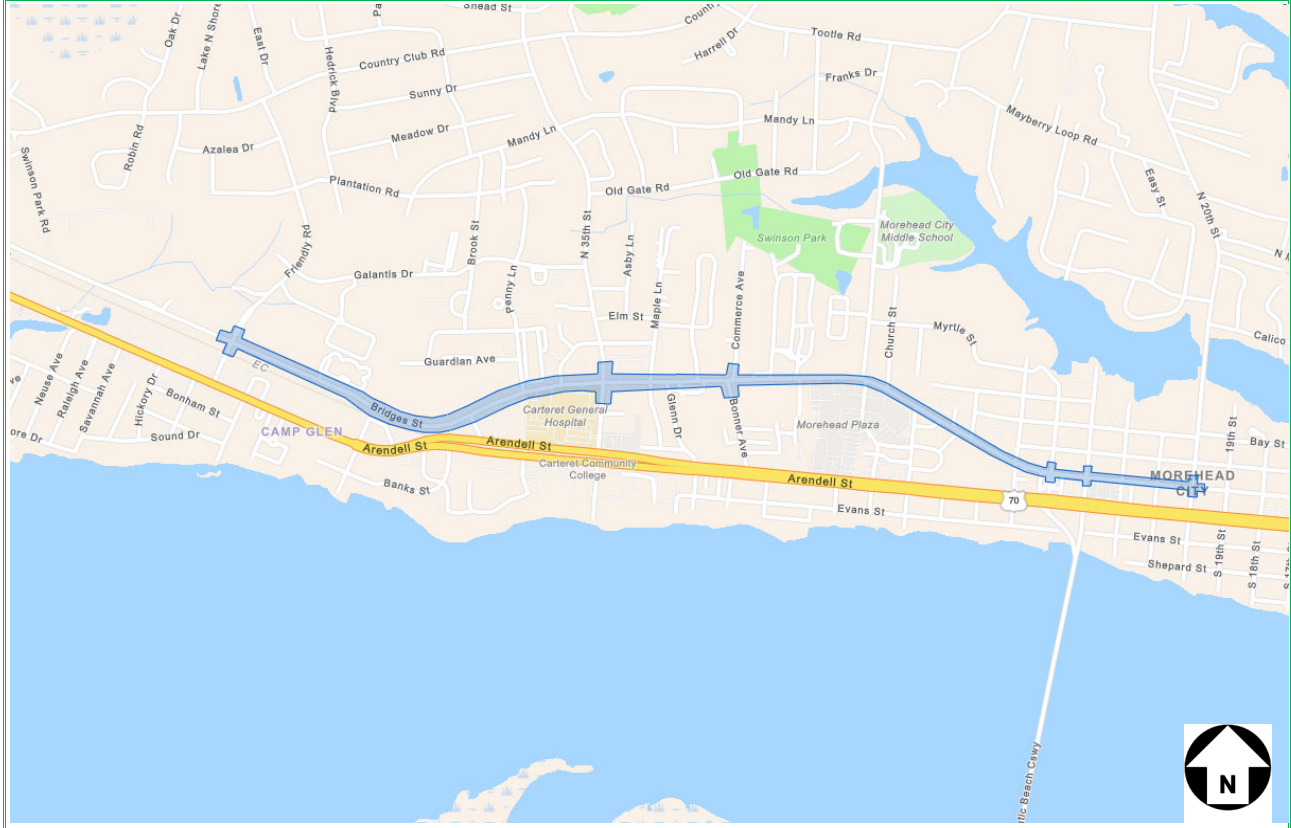

| ID | Road Name | External | 2025 AADT | 2035 AADT | ID | Road Name | External | 2025 AADT | 2035 AADT |
|-----|-----------------------|----------|-----------|-----------|-----|----------------------|----------|-----------|-----------|
| 01N | SR 1605 (Friendly Rd) | Yes | 4,700 | 5,200 | 06N | SR 1176 (N 20th St) | Yes | 7,100 | 7,600 |
| 01E | SR 1738 (Bridges St) | No | 16,500 | 17,700 | 06E | Bridges St | Yes | 7,900 | 8,700 |
| 01S | SR 1605 (Friendly Rd) | Yes | 4,800 | 5,300 | 06S | SR 1627 (N 20th St) | Yes | 2,500 | 2,800 |
| 01W | SR 1738 (Bridges St) | Yes | 15,500 | 16,600 | 06W | SR 1176 (Bridges St) | No | 10,800 | 11,300 |
| 02N | SR 1602 (N 35th St) | Yes | 6,900 | 7,600 | | | | | |
| 02E | SR 1176 (Bridges St) | No | 15,000 | 15,700 | | | | | |
| 02S | SR 1602 (N 35th St) | Yes | 4,500 | 5,000 | | | | | |
| 02W | SR 1176 (Bridges St) | No | 16,500 | 17,200 | | | | | |
| 03N | Commerce Ave | Yes | 1,600 | 1,800 | | | | | |
| 03E | SR 1176 (Bridges St) | No | 13,500 | 14,100 | | | | | |
| 03S | Bonner Ave | Yes | 900 | 1,000 | | | | | |
| 03W | SR 1176 (Bridges St) | No | 15,000 | 15,700 | | | | | |
| 04N | N 24th St | Yes | 300 | 300 | | | | | |
| 04E | SR 1176 (Bridges St) | No | 12,300 | 12,800 | | | | | |
| 04S | SR 1749 (N 24th St) | Yes | 2,300 | 2,500 | | | | | |
| 04W | SR 1176 (Bridges St) | No | 13,500 | 14,100 | | | | | |
| 05N | N 23rd St | Yes | 500 | 600 | | | | | |
| 05E | SR 1176 (Bridges St) | No | 10,800 | 11,300 | | | | | |
| 05S | SR 1748 (N 23rd St) | Yes | 2,300 | 2,500 | | | | | |
| 05W | SR 1176 (Bridges St) | No | 12,300 | 12,800 | | | | | |

| | |
|---------------------------------|----------|
| 2025 AM Peak Travel Time Saving | -11 |
| 2025 PM Peak Travel Time Saving | -7 |
| 2025 Total Daily Vehicles | 30,900 |
| 2025 Daily Travel Time Savings | -41.4 |
| 2035 AM Peak Travel Time Saving | -1 |
| 2035 PM Peak Travel Time Saving | -3 |
| 2035 Total Daily Vehicles | 33,750 |
| 2035 Daily Travel Time Savings | -8.0 |
| Days per Year | 260 |
| Travel Time Savings Duration | 10 Years |

| Existing Congestion Level | Non-Congested |
|---------------------------------|---------------|
| Daily Savings Conversion Factor | 2.25 |

| 10-year Travel Time Savings | | | |
|---------------------------------|------------|------|------------|
| -64,000 hours | | | |
| Travel Time Savings Per Vehicle | | | |
| 2025 | -5 sec/veh | 2035 | -1 sec/veh |

Description of Proposed Design

Intersection Improvements: Friendly St - Add EB and WB right turn lanes; 35th St - Add WB and SB right turn lanes; Bonner/Commerce - Signalize and add turn lanes as needed; 20th - Extend EB left turn lane

| BASE YEAR | 2025 | FUTURE YEAR | 2035 | REPORT STATUS | Final | CORRIDOR PROJECT | Yes |
|-----------|------|-------------|------|---------------|-------|------------------|-----|
|-----------|------|-------------|------|---------------|-------|------------------|-----|



Figure 1

Existing Conditions

SHEET 1 OF 1

LEGEND

| | | | |
|--------------|--|-----------|-----------|
| TIP: | -- | WBS: | 34263.1.1 |
| COUNTY: | Carteret | DIVISION: | 2 |
| DATE: | February 19, 2026 | | |
| PREPARED BY: | Three Oaks Engineering | | |
| LOCATION: | SR 1738 (Bridges Street) from Friendly Rd to 20th Street | | |
| PROJECT: | 25 - Improve Multiple Intersections along Corridor | | |

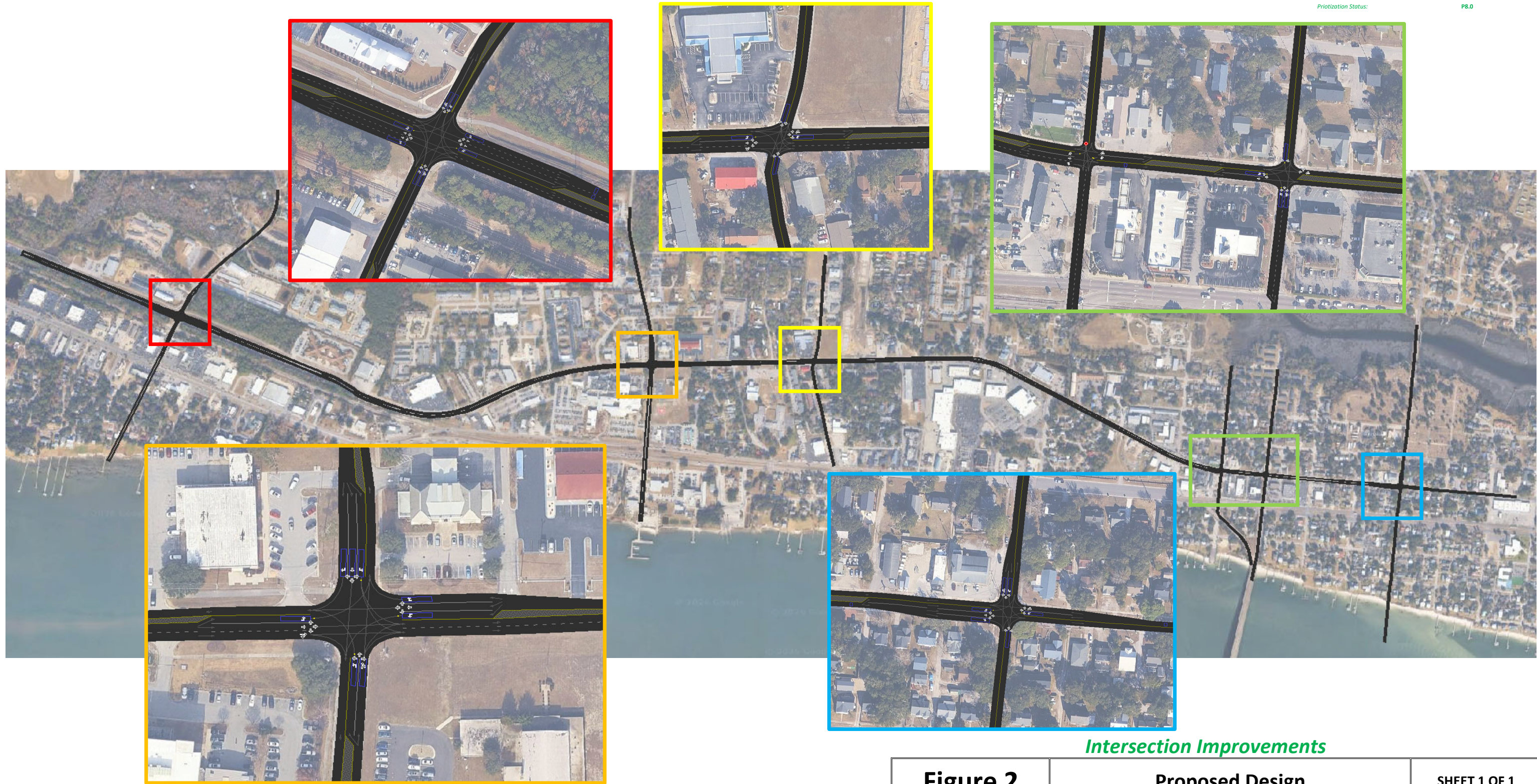

Intersection Improvements



| | | | |
|-----------------|--|----------------|---------------------|
| Figure 2 | Proposed Design | | SHEET 1 OF 1 |
| | LEGEND | | |
| | TIP: -- | WBS: 34263.1.1 | |
| | COUNTY: Carteret | DIVISION: 2 | |
| | DATE: February 19, 2026 | | |
| | PREPARED BY: Three Oaks Engineering | | |
| | LOCATION: SR 1738 (Bridges Street) from Friendly Rd to 20th Street | | |
| | PROJECT: 25 - Improve Multiple Intersections along Corridor | | |



SPOT Volume Report



SR 1738 (Bridges Street) from Friendly Rd to 20th Street 25 - Improve Multiple Intersections along Corridor

STIP No. -- SPOT ID: H250723 WBS No. 34263.1.1
Carteret DIVISION: 2

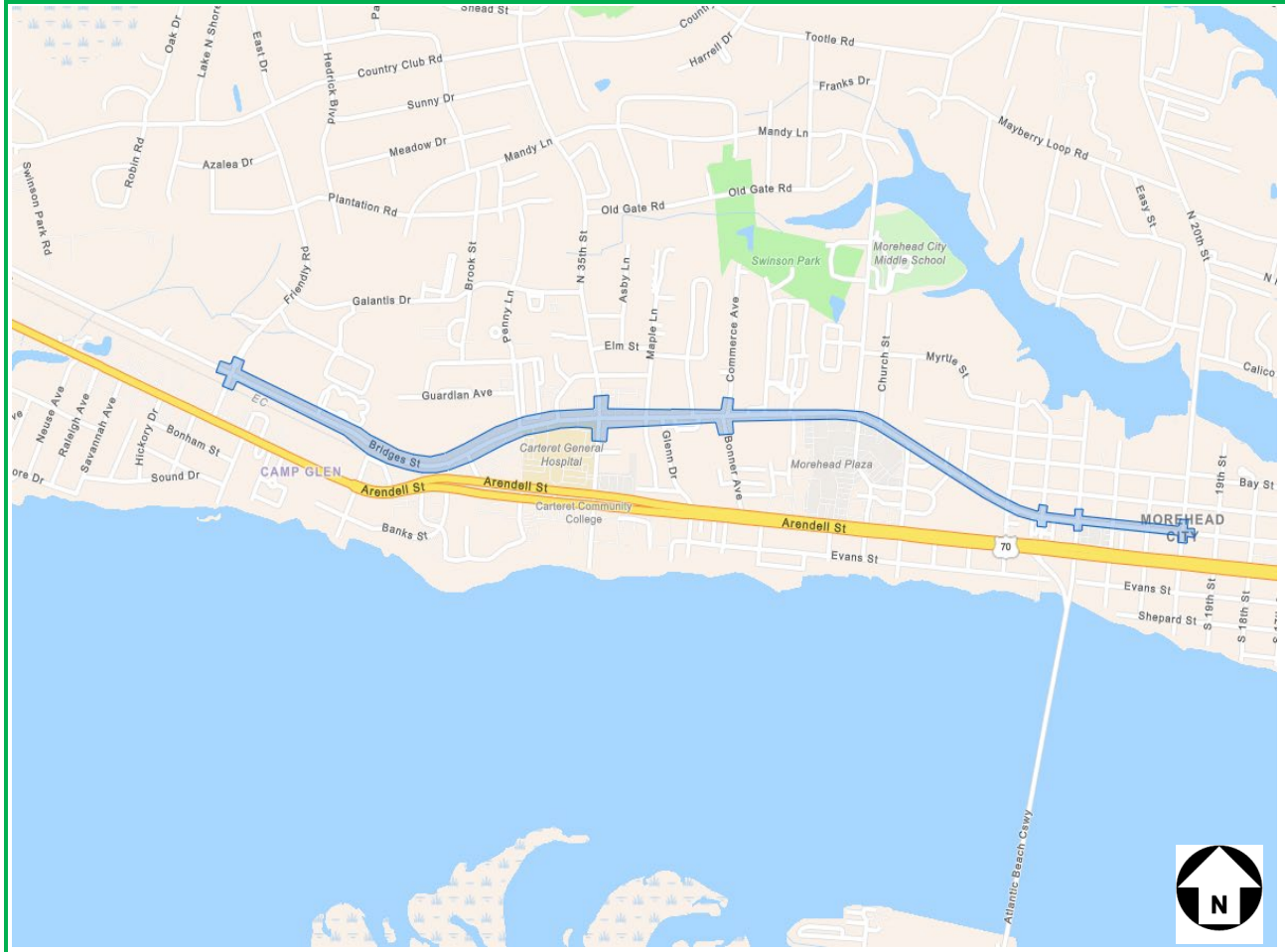

PROJECT STUDY AREA

PREPARED BY: Three Oaks Engineering
2/10/2026



Committed Projects in Study Area

| | |
|-------------------------------|-----|
| STIP Project and Description: | N/A |
| NCDOT STIP 2026-2035 | |

Traffic Count Data

| Int ID | Count ID | Count Date | Intersection | AADT Source | 2023 NCDOT AADT Web Map | Version |
|--------|----------|------------|--|------------------------------|--|---------|
| 1 | 11478 | 8/15/2023 | SR 1738 (Bridges St) @ SR 1605 (Friendly Rd) | Travel Demand Model Utilized | North Carolina Statewide Model (NCSTM) | Gen 4.5 |
| 2 | 11479 | 8/15/2023 | SR 1176 (Bridges St) @ SR 1602 (N 35th St) | | | |
| 3 | 19383 | 11/12/2025 | SR 1176 (Bridges St) @ Commerce Ave/Bonner Ave | | | |
| 4 | 11480 | 8/15/2023 | SR 1176 (Bridges St) @ SR 1749 (N 24th St)/N 24th St | | | |
| 5 | 11481 | 8/15/2023 | SR 1176 (Bridges St) @ SR 1748 (N 23rd St)/N 23rd St | | | |
| 6 | 19384 | 11/12/2025 | SR 1176 (Bridges St) @ SR 1176 (N 20th St)/SR 1627 (N 20th St) | | | |

| | |
|---------------|----------------------------|
| BASE YEAR | 2025 |
| FUTURE YEAR | 2035 |
| REPORT STATUS | Final CORRIDOR PROJECT Yes |

AADT DATA (SPOT)

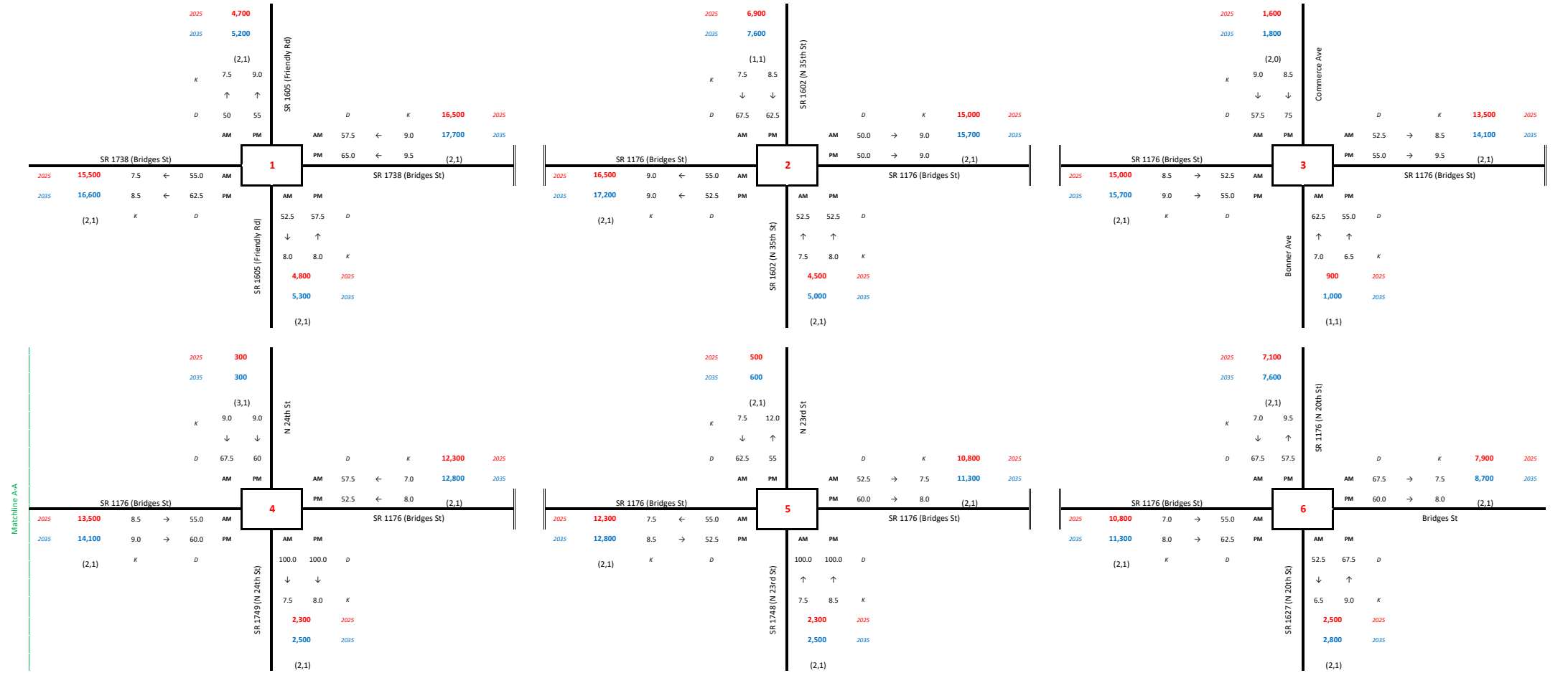

| 2025/2035 | | SPOT Traffic Volumes | | SHEET 1 OF 1 | |
|---|--|---|--|--|--|
| <p>LEGEND</p> <p>## Intersection Number</p> <p>K Design Hour Factor</p> <p>D Directional Distribution</p> <p>(Dual, TTST) Heavy Vehicle Percentage (Dual, TTST)</p> <p>2025 Base Year AADT Volume</p> <p>2035 Future Year AADT Volume</p> | | <p>TIP: --</p> <p>COUNTY: Carteret</p> <p>DATE: February 10, 2026</p> <p>PREPARED BY: Three Oaks Engineering</p> <p>LOCATION: SR 1738 (Bridges Street) from Friendly Rd to 20th Street</p> <p>PROJECT: 25 - Improve Multiple Intersections along Corridor</p> | | <p>WBS: 34263.1.1</p> <p>DIVISION: 2</p> | |

Prioritization Status: P8.0

TURNING MOVEMENT VOLUMES (SPOT)

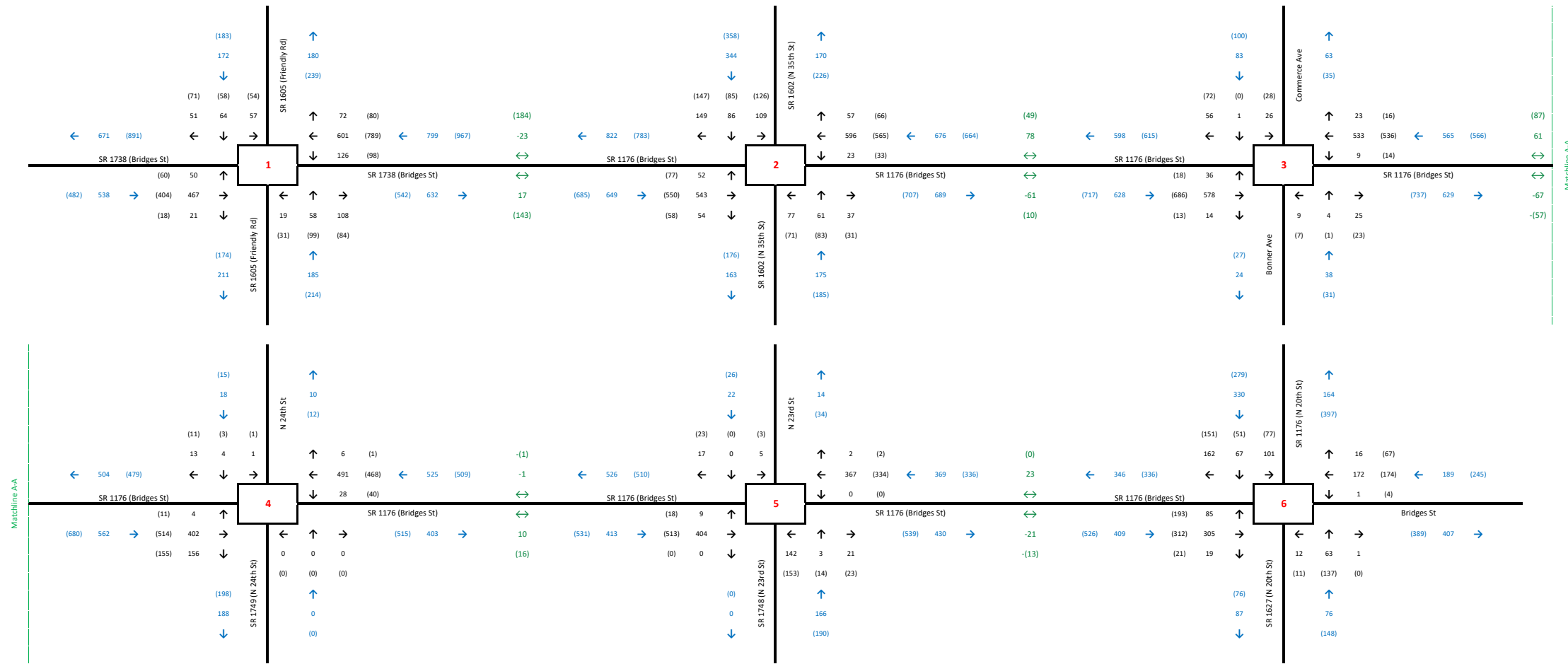

Prioritization Status: P8.0

UNBALANCED

2025

Base Year (Existing)

SHEET 1 OF 1

LEGEND

- ##** Intersection Number
- AM (PM) Peak Hour Intersection Volume
- AM (PM) Peak Hour Approach Volume
- AM (PM) Peak Hour Volume Balancing



| | | | |
|--------------|--|-----------|-----------|
| TIP: | -- | WBS: | 34263.1.1 |
| COUNTY: | Carteret | DIVISION: | 2 |
| DATE: | February 10, 2026 | | |
| PREPARED BY: | Three Oaks Engineering | | |
| LOCATION: | SR 1738 (Bridges Street) from Friendly Rd to 20th Street | | |
| PROJECT: | 25 - Improve Multiple Intersections along Corridor | | |

TURNING MOVEMENT VOLUMES (SPOT)

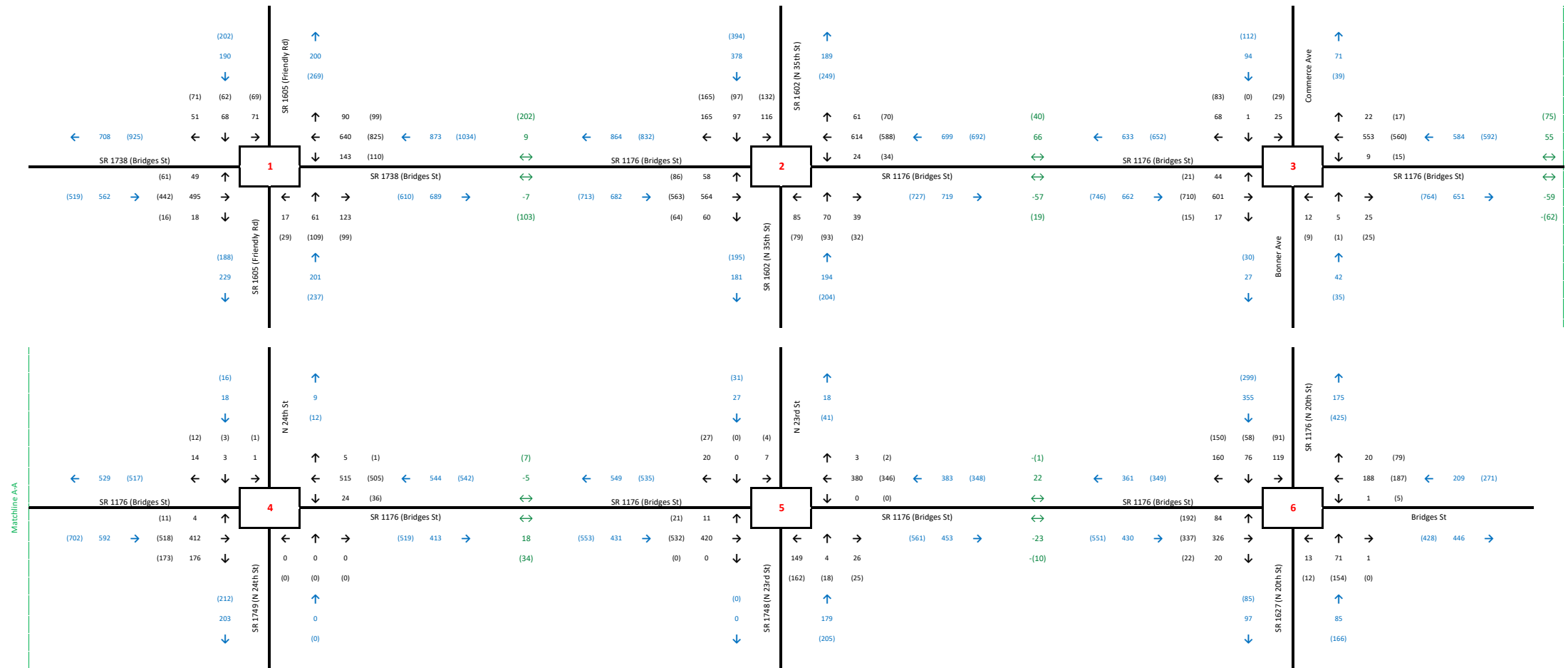

Prioritization Status: P8.0

UNBALANCED

2035

Future Year Build

SHEET 1 OF 1

LEGEND

- ##** Intersection Number
- AM (PM) Peak Hour Intersection Volume
- AM (PM) Peak Hour Approach Volume
- AM (PM) Peak Hour Volume Balancing



| | | | |
|--------------|--|-----------|-----------|
| TIP: | -- | WBS: | 34263.1.1 |
| COUNTY: | Carteret | DIVISION: | 2 |
| DATE: | February 10, 2026 | | |
| PREPARED BY: | Three Oaks Engineering | | |
| LOCATION: | SR 1738 (Bridges Street) from Friendly Rd to 20th Street | | |
| PROJECT: | 25 - Improve Multiple Intersections along Corridor | | |

ORIGIN-DESTINATION MATRICES (SPOT)

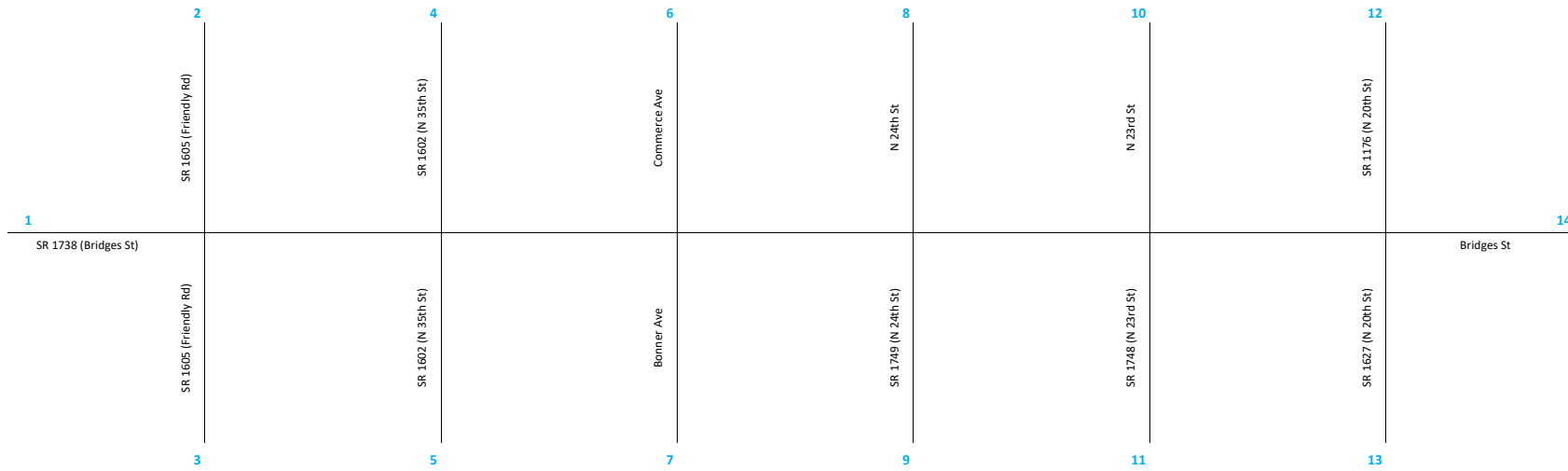

| AM | 1 | 2 | 3 | 4 | 5 | 6 | 7 | 8 | 9 | 10 | 11 | 12 | 13 | 14 | Total |
|-------|-----|-----|-----|-----|-----|----|----|----|-----|----|----|-----|----|-----|-------|
| 1 | 0 | 55 | 24 | 46 | 46 | 27 | 5 | 3 | 95 | 5 | 0 | 49 | 12 | 170 | 537 |
| 2 | 56 | 0 | 68 | 5 | 5 | 3 | 1 | 0 | 10 | 1 | 0 | 5 | 1 | 18 | 173 |
| 3 | 22 | 62 | 0 | 10 | 10 | 6 | 1 | 1 | 21 | 1 | 0 | 11 | 3 | 38 | 186 |
| 4 | 132 | 14 | 26 | 0 | 83 | 3 | 7 | 1 | 23 | 1 | 0 | 12 | 3 | 41 | 346 |
| 5 | 66 | 7 | 13 | 59 | 0 | 1 | 2 | 0 | 8 | 0 | 0 | 4 | 1 | 13 | 174 |
| 6 | 42 | 4 | 8 | 5 | 2 | 0 | 1 | 0 | 3 | 0 | 0 | 4 | 1 | 12 | 82 |
| 7 | 8 | 1 | 2 | 1 | 0 | 4 | 0 | 0 | 3 | 0 | 0 | 4 | 1 | 13 | 37 |
| 8 | 9 | 1 | 2 | 1 | 0 | 0 | 0 | 0 | 4 | 0 | 0 | 0 | 0 | 0 | 17 |
| 9 | 0 | 0 | 0 | 0 | 0 | 0 | 0 | 0 | 0 | 0 | 0 | 0 | 0 | 0 | 0 |
| 10 | 11 | 1 | 2 | 1 | 1 | 1 | 0 | 0 | 1 | 0 | 0 | 0 | 0 | 3 | 21 |
| 11 | 91 | 10 | 18 | 11 | 4 | 5 | 2 | 1 | 6 | 3 | 0 | 2 | 0 | 14 | 167 |
| 12 | 113 | 12 | 23 | 14 | 6 | 6 | 2 | 2 | 7 | 1 | 0 | 0 | 63 | 82 | 331 |
| 13 | 9 | 1 | 2 | 1 | 0 | 0 | 0 | 0 | 1 | 0 | 0 | 60 | 0 | 1 | 75 |
| 14 | 109 | 11 | 22 | 13 | 5 | 6 | 2 | 2 | 7 | 1 | 0 | 12 | 1 | 0 | 191 |
| Total | 668 | 179 | 210 | 167 | 162 | 62 | 23 | 10 | 189 | 13 | 0 | 163 | 86 | 405 | 2337 |

| PM | 1 | 2 | 3 | 4 | 5 | 6 | 7 | 8 | 9 | 10 | 11 | 12 | 13 | 14 | Total |
|-------|-----|-----|-----|-----|-----|----|----|----|-----|----|----|-----|----|-----|-------|
| 1 | 0 | 60 | 19 | 56 | 41 | 11 | 3 | 5 | 80 | 9 | 0 | 88 | 10 | 139 | 521 |
| 2 | 79 | 0 | 61 | 7 | 6 | 1 | 0 | 1 | 11 | 1 | 0 | 12 | 1 | 19 | 199 |
| 3 | 35 | 101 | 0 | 12 | 9 | 2 | 1 | 1 | 17 | 2 | 0 | 19 | 2 | 30 | 231 |
| 4 | 152 | 13 | 17 | 0 | 82 | 3 | 7 | 2 | 27 | 3 | 0 | 30 | 3 | 48 | 387 |
| 5 | 74 | 6 | 8 | 82 | 0 | 1 | 2 | 0 | 7 | 1 | 0 | 7 | 1 | 12 | 201 |
| 6 | 61 | 5 | 7 | 7 | 3 | 0 | 0 | 1 | 4 | 1 | 0 | 8 | 1 | 12 | 110 |
| 7 | 7 | 1 | 1 | 1 | 0 | 1 | 0 | 1 | 3 | 1 | 0 | 7 | 1 | 11 | 35 |
| 8 | 9 | 1 | 1 | 1 | 0 | 0 | 0 | 0 | 3 | 0 | 0 | 0 | 0 | 0 | 15 |
| 9 | 0 | 0 | 0 | 0 | 0 | 0 | 0 | 0 | 0 | 0 | 0 | 0 | 0 | 0 | 0 |
| 10 | 17 | 1 | 2 | 2 | 1 | 1 | 0 | 0 | 1 | 0 | 0 | 1 | 0 | 2 | 28 |
| 11 | 116 | 10 | 13 | 13 | 6 | 4 | 3 | 0 | 9 | 13 | 0 | 4 | 0 | 16 | 207 |
| 12 | 122 | 11 | 14 | 13 | 7 | 4 | 3 | 0 | 9 | 1 | 0 | 0 | 48 | 72 | 304 |
| 13 | 11 | 1 | 1 | 1 | 1 | 0 | 0 | 0 | 1 | 0 | 0 | 142 | 0 | 0 | 158 |
| 14 | 142 | 12 | 16 | 15 | 7 | 4 | 4 | 0 | 11 | 1 | 0 | 50 | 3 | 0 | 265 |
| Total | 825 | 222 | 160 | 210 | 163 | 32 | 23 | 11 | 183 | 33 | 0 | 368 | 70 | 361 | 2661 |

Prioritization Status:

P8.0

| | |
|--|-----------------------------|
| 2025 | Base Year (Existing) |
| TIP: -- | 34263.1.1 |
| COUNTY: Carteret | DIVISION: 2 |
| DATE: February 10, 2026 | |
| PREPARED BY: Three Oaks Engineering | |
| LOCATION: SR 1738 (Bridges Street) from Friendly Rd to 20th Street | |
| PROJECT: 25 - Improve Multiple Intersections along Corridor | |

ORIGIN-DESTINATION MATRICES (SPOT)

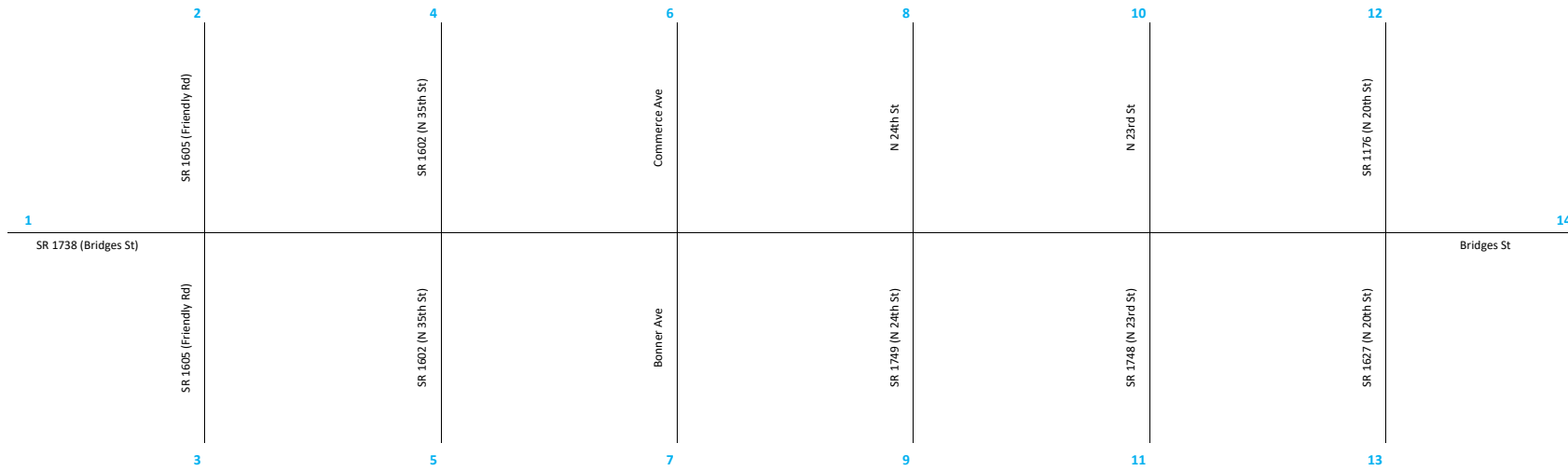

| AM | 1 | 2 | 3 | 4 | 5 | 6 | 7 | 8 | 9 | 10 | 11 | 12 | 13 | 14 | Total |
|-------|-----|-----|-----|-----|-----|----|----|---|-----|----|----|-----|----|-----|-------|
| 1 | 0 | 54 | 20 | 50 | 49 | 31 | 6 | 2 | 104 | 6 | 0 | 48 | 13 | 177 | 560 |
| 2 | 56 | 0 | 73 | 6 | 6 | 4 | 1 | 0 | 13 | 1 | 0 | 6 | 2 | 23 | 191 |
| 3 | 19 | 66 | 0 | 12 | 12 | 7 | 1 | 1 | 25 | 2 | 0 | 12 | 3 | 42 | 202 |
| 4 | 142 | 18 | 30 | 0 | 93 | 4 | 8 | 1 | 25 | 2 | 0 | 12 | 3 | 43 | 381 |
| 5 | 71 | 9 | 15 | 68 | 0 | 1 | 3 | 0 | 8 | 1 | 0 | 4 | 1 | 14 | 195 |
| 6 | 49 | 6 | 10 | 6 | 2 | 0 | 1 | 0 | 3 | 0 | 0 | 3 | 1 | 12 | 93 |
| 7 | 10 | 1 | 2 | 1 | 0 | 5 | 0 | 0 | 3 | 0 | 0 | 4 | 1 | 13 | 40 |
| 8 | 9 | 1 | 2 | 1 | 0 | 0 | 0 | 0 | 3 | 0 | 0 | 0 | 0 | 0 | 16 |
| 9 | 0 | 0 | 0 | 0 | 0 | 0 | 0 | 0 | 0 | 0 | 0 | 0 | 0 | 0 | 0 |
| 10 | 13 | 2 | 3 | 2 | 1 | 1 | 0 | 0 | 1 | 0 | 0 | 1 | 0 | 5 | 29 |
| 11 | 95 | 12 | 20 | 12 | 4 | 5 | 2 | 1 | 5 | 4 | 0 | 2 | 0 | 17 | 179 |
| 12 | 112 | 14 | 24 | 14 | 5 | 6 | 2 | 1 | 6 | 1 | 0 | 0 | 72 | 98 | 355 |
| 13 | 9 | 1 | 2 | 1 | 0 | 0 | 0 | 0 | 1 | 0 | 0 | 68 | 0 | 1 | 83 |
| 14 | 118 | 15 | 25 | 15 | 5 | 6 | 2 | 1 | 6 | 1 | 0 | 16 | 1 | 0 | 211 |
| Total | 703 | 199 | 226 | 188 | 177 | 70 | 26 | 7 | 203 | 18 | 0 | 176 | 97 | 445 | 2535 |

| PM | 1 | 2 | 3 | 4 | 5 | 6 | 7 | 8 | 9 | 10 | 11 | 12 | 13 | 14 | Total |
|-------|-----|-----|-----|-----|-----|----|----|----|-----|----|----|-----|----|-----|-------|
| 1 | 0 | 62 | 17 | 61 | 45 | 13 | 4 | 5 | 89 | 10 | 0 | 89 | 10 | 151 | 556 |
| 2 | 78 | 0 | 65 | 10 | 7 | 2 | 1 | 1 | 14 | 2 | 0 | 14 | 2 | 23 | 219 |
| 3 | 33 | 112 | 0 | 14 | 10 | 3 | 1 | 1 | 20 | 2 | 0 | 20 | 2 | 35 | 253 |
| 4 | 165 | 17 | 20 | 0 | 94 | 3 | 8 | 2 | 29 | 3 | 0 | 29 | 3 | 50 | 423 |
| 5 | 79 | 8 | 10 | 91 | 0 | 1 | 2 | 0 | 7 | 1 | 0 | 7 | 1 | 12 | 219 |
| 6 | 68 | 7 | 8 | 8 | 4 | 0 | 0 | 1 | 4 | 1 | 0 | 7 | 1 | 13 | 122 |
| 7 | 8 | 1 | 1 | 1 | 0 | 1 | 0 | 1 | 4 | 1 | 0 | 7 | 1 | 12 | 38 |
| 8 | 9 | 1 | 1 | 1 | 0 | 0 | 0 | 0 | 3 | 0 | 0 | 0 | 0 | 0 | 15 |
| 9 | 0 | 0 | 0 | 0 | 0 | 0 | 0 | 0 | 0 | 0 | 0 | 0 | 0 | 0 | 0 |
| 10 | 20 | 2 | 2 | 2 | 1 | 1 | 1 | 0 | 1 | 0 | 0 | 1 | 0 | 3 | 34 |
| 11 | 120 | 12 | 15 | 13 | 6 | 4 | 3 | 0 | 8 | 17 | 0 | 4 | 0 | 17 | 219 |
| 12 | 119 | 12 | 15 | 13 | 6 | 4 | 4 | 0 | 8 | 1 | 0 | 0 | 55 | 84 | 321 |
| 13 | 12 | 1 | 1 | 1 | 1 | 0 | 0 | 0 | 1 | 0 | 0 | 159 | 0 | 0 | 176 |
| 14 | 150 | 15 | 18 | 17 | 8 | 5 | 4 | 0 | 10 | 1 | 0 | 59 | 4 | 0 | 291 |
| Total | 861 | 250 | 173 | 232 | 182 | 37 | 28 | 11 | 198 | 39 | 0 | 396 | 79 | 400 | 2886 |



Prioritization Status:

P8.0

| | |
|--|--------------------------|
| 2035 | Future Year Build |
| TIP: -- | 34263.1.1 |
| COUNTY: Carteret | DIVISION: 2 |
| DATE: February 10, 2026 | |
| PREPARED BY: Three Oaks Engineering | |
| LOCATION: SR 1738 (Bridges Street) from Friendly Rd to 20th Street | |
| PROJECT: 25 - Improve Multiple Intersections along Corridor | |

| | | | | |
|----|----------------|-----------|-----------------|---|
| -- | H250723 | 01 | Carteret | SR 1738 (Bridges St) @ SR 1605 (Friendly Rd) |
|----|----------------|-----------|-----------------|---|

STIP No. SPOT ID Int. No. County Intersection Location

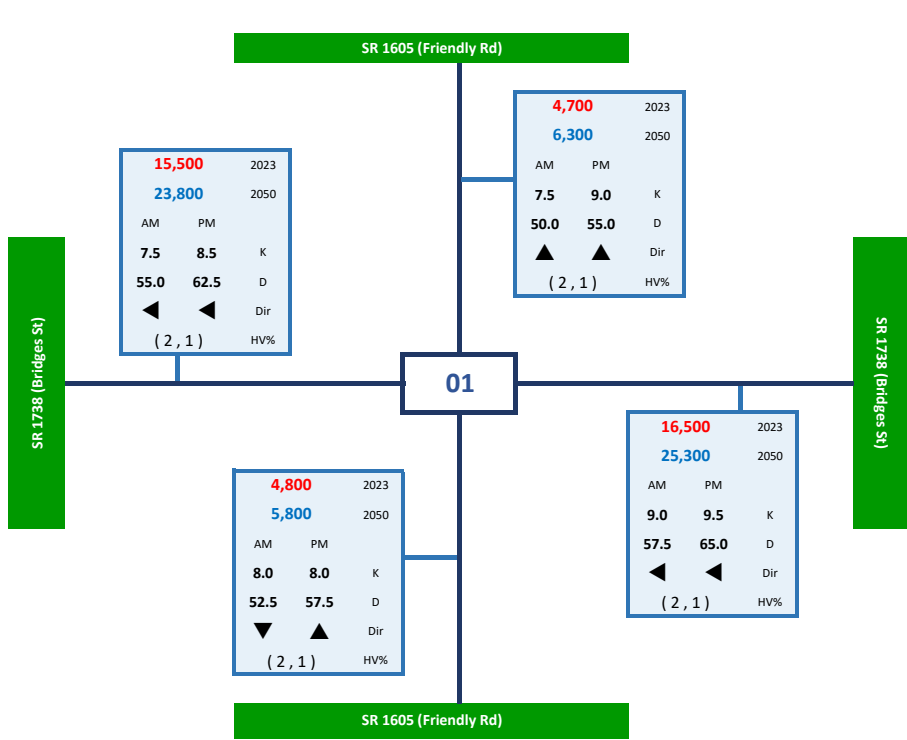

| Express Design Turn Volumes | | | | | |
|-----------------------------|----|---------------------|-----|---|-----|
| SR 1605 (Friendly Rd) | | | | | |
| | 51 | 64 | 57 | | |
| | ← | ↓ | → | | |
| 50 | ↑ | | | ↑ | 72 |
| 467 | → | 2023 AM Peak | | ← | 601 |
| 21 | ↓ | | | ↓ | 126 |
| | ← | ↑ | → | | |
| | 19 | 58 | 108 | | |
| SR 1605 (Friendly Rd) | | | | | |

| Prioritization Turn Volumes | | | | | |
|-----------------------------|----|---------------------|-----|---|-----|
| SR 1605 (Friendly Rd) | | | | | |
| | 51 | 64 | 57 | | |
| | ← | ↓ | → | | |
| 50 | ↑ | | | ↑ | 72 |
| 467 | → | 2025 AM Peak | | ← | 601 |
| 21 | ↓ | | | ↓ | 126 |
| | ← | ↑ | → | | |
| | 19 | 58 | 108 | | |
| SR 1605 (Friendly Rd) | | | | | |

| Express Design Turn Volumes | | | | | |
|-----------------------------|----|---------------------|----|---|-----|
| SR 1605 (Friendly Rd) | | | | | |
| | 71 | 58 | 54 | | |
| | ← | ↓ | → | | |
| 60 | ↑ | | | ↑ | 80 |
| 404 | → | 2023 PM Peak | | ← | 789 |
| 18 | ↓ | | | ↓ | 98 |
| | ← | ↑ | → | | |
| | 31 | 99 | 84 | | |
| SR 1605 (Friendly Rd) | | | | | |

| Prioritization Turn Volumes | | | | | |
|-----------------------------|----|---------------------|----|---|-----|
| SR 1605 (Friendly Rd) | | | | | |
| | 71 | 58 | 54 | | |
| | ← | ↓ | → | | |
| 60 | ↑ | | | ↑ | 80 |
| 404 | → | 2025 PM Peak | | ← | 789 |
| 18 | ↓ | | | ↓ | 98 |
| | ← | ↑ | → | | |
| | 31 | 99 | 84 | | |
| SR 1605 (Friendly Rd) | | | | | |

| Express Design Turn Volumes | | | | | |
|-----------------------------|----|---------------------|-----|---|-----|
| SR 1605 (Friendly Rd) | | | | | |
| | 63 | 67 | 101 | | |
| | ← | ↓ | → | | |
| 60 | ↑ | | | ↑ | 124 |
| 735 | → | 2050 AM Peak | | ← | 942 |
| 19 | ↓ | | | ↓ | 167 |
| | ← | ↑ | → | | |
| | 17 | 59 | 144 | | |
| SR 1605 (Friendly Rd) | | | | | |

| Prioritization Turn Volumes | | | | | |
|-----------------------------|----|---------------------|-----|---|-----|
| SR 1605 (Friendly Rd) | | | | | |
| | 51 | 68 | 71 | | |
| | ← | ↓ | → | | |
| 49 | ↑ | | | ↑ | 90 |
| 495 | → | 2035 AM Peak | | ← | 640 |
| 18 | ↓ | | | ↓ | 143 |
| | ← | ↑ | → | | |
| | 17 | 61 | 123 | | |
| SR 1605 (Friendly Rd) | | | | | |

| Express Design Turn Volumes | | | | | |
|-----------------------------|----|---------------------|-----|---|------|
| SR 1605 (Friendly Rd) | | | | | |
| | 89 | 62 | 94 | | |
| | ← | ↓ | → | | |
| 78 | ↑ | | | ↑ | 136 |
| 656 | → | 2050 PM Peak | | ← | 1208 |
| 18 | ↓ | | | ↓ | 127 |
| | ← | ↑ | → | | |
| | 32 | 110 | 118 | | |
| SR 1605 (Friendly Rd) | | | | | |

| Prioritization Turn Volumes | | | | | |
|-----------------------------|----|---------------------|----|---|-----|
| SR 1605 (Friendly Rd) | | | | | |
| | 71 | 62 | 69 | | |
| | ← | ↓ | → | | |
| 61 | ↑ | | | ↑ | 99 |
| 442 | → | 2035 PM Peak | | ← | 825 |
| 16 | ↓ | | | ↓ | 110 |
| | ← | ↑ | → | | |
| | 29 | 109 | 99 | | |
| SR 1605 (Friendly Rd) | | | | | |

| Approach | Road Name | Route Type | No. of Lanes | Facility Type | Functional Class | Capacity | 2023 V/C Ratio |
|----------|-----------------------|------------|--------------|---------------|------------------|----------|----------------|
| North | SR 1605 (Friendly Rd) | SR | 2 | Arterial | Collector | 15,843 | 0.30 |
| East | SR 1738 (Bridges St) | SR | 2 | Arterial | Arterial | 15,843 | 1.04 |
| South | SR 1605 (Friendly Rd) | SR | 2 | Arterial | Collector | 15,843 | 0.30 |
| West | SR 1738 (Bridges St) | SR | 4 | Arterial | Arterial | 31,719 | 0.49 |

| Approach | Road Name | Express Design Traffic Volumes | | | Prioritization Traffic Volumes | | |
|----------|-----------------------|--------------------------------|----------------|-----------|--------------------------------|----------------|-----------|
| | | 2023 AADT | 2023-2050 CAGR | 2050 AADT | 2025 AADT | 2025-2035 CAGR | 2035 AADT |
| North | SR 1605 (Friendly Rd) | 4,700 | 1.1% | 6,300 | 4,700 | 1.0% | 5,200 |
| East | SR 1738 (Bridges St) | 16,500 | 1.6% | 25,300 | 16,500 | 0.7% | 17,700 |
| South | SR 1605 (Friendly Rd) | 4,800 | 0.7% | 5,800 | 4,800 | 1.0% | 5,300 |
| West | SR 1738 (Bridges St) | 15,500 | 1.6% | 23,800 | 15,500 | 0.7% | 16,600 |

-- **H250723** **02** **Carteret** **SR 1176 (Bridges St)@ SR 1602 (N 35th St)**

STIP No. SPOT ID Int. No. County Intersection Location

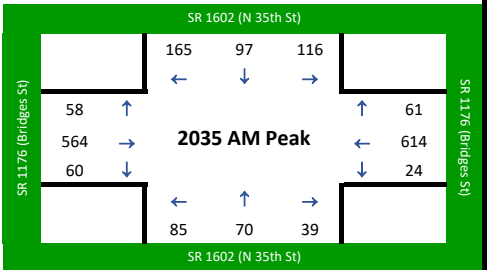
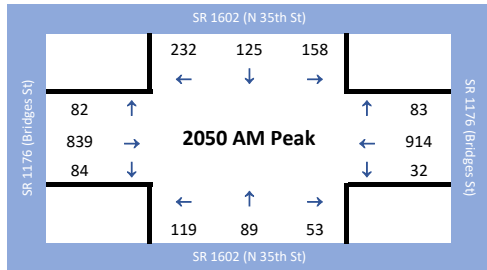
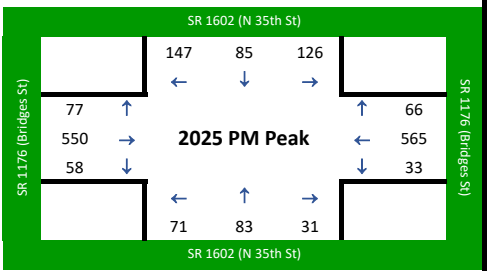
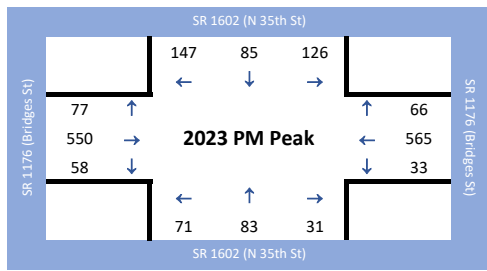
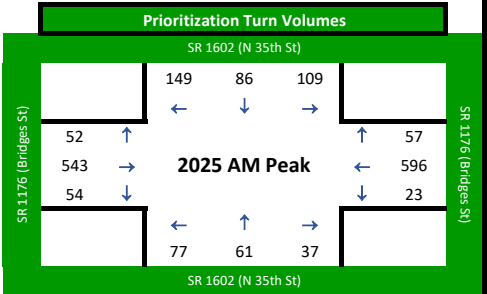
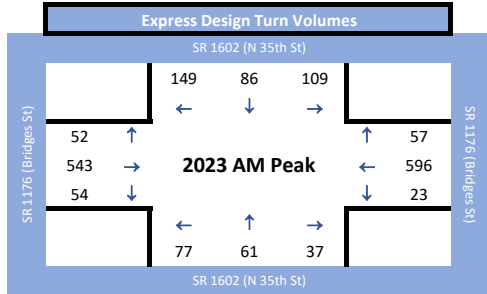
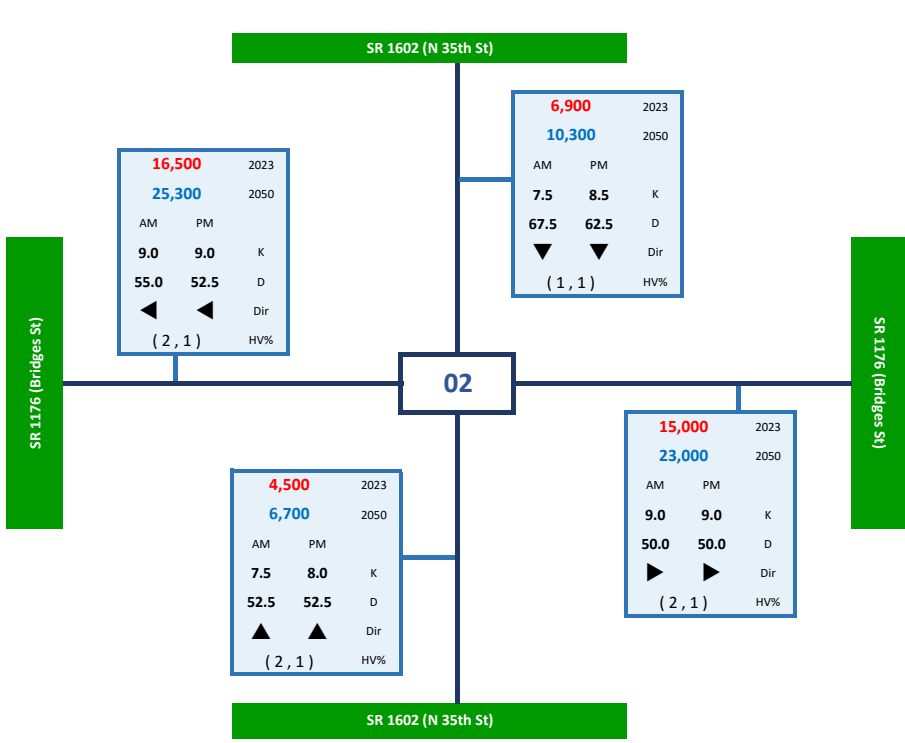

| Approach | Road Name | Route Type | No. of Lanes | Facility Type | Functional Class | Capacity | 2023 V/C Ratio |
|----------|----------------------|------------|--------------|---------------|------------------|----------|----------------|
| North | SR 1602 (N 35th St) | SR | 2 | Arterial | Collector | 15,843 | 0.44 |
| East | SR 1176 (Bridges St) | SR | 2 | Arterial | Arterial | 15,843 | 0.95 |
| South | SR 1602 (N 35th St) | SR | 2 | Arterial | Collector | 15,843 | 0.28 |
| West | SR 1176 (Bridges St) | SR | 2 | Arterial | Arterial | 15,843 | 1.04 |

| Approach | Road Name | Express Design Traffic Volumes | | | Prioritization Traffic Volumes | | |
|----------|----------------------|--------------------------------|----------------|-----------|--------------------------------|----------------|-----------|
| | | 2023 AADT | 2023-2050 CAGR | 2050 AADT | 2025 AADT | 2025-2035 CAGR | 2035 AADT |
| North | SR 1602 (N 35th St) | 6,900 | 1.5% | 10,300 | 6,900 | 1.0% | 7,600 |
| East | SR 1176 (Bridges St) | 15,000 | 1.6% | 23,000 | 15,000 | 0.4% | 15,700 |
| South | SR 1602 (N 35th St) | 4,500 | 1.5% | 6,700 | 4,500 | 1.0% | 5,000 |
| West | SR 1176 (Bridges St) | 16,500 | 1.6% | 25,300 | 16,500 | 0.4% | 17,200 |

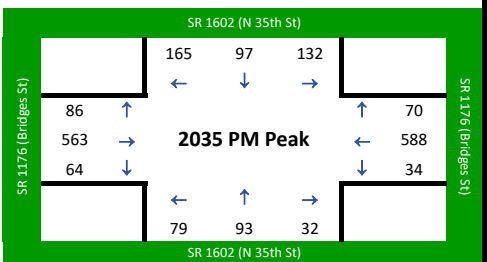
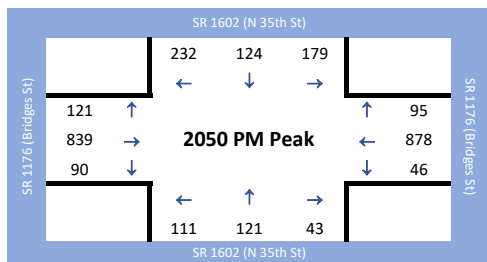

| | | | | |
|----|---------|----|----------|--|
| -- | H250723 | 03 | Carteret | SR 1176 (Bridges St) @ Commerce Ave/Bonner Ave |
|----|---------|----|----------|--|

STIP No. SPOT ID Int. No. County Intersection Location

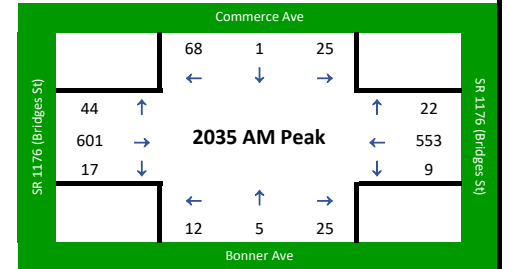
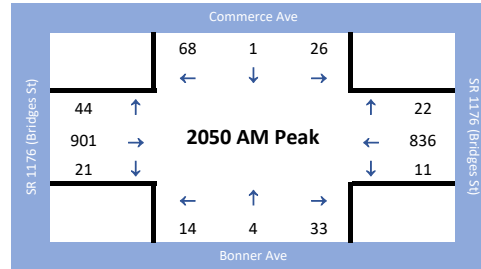
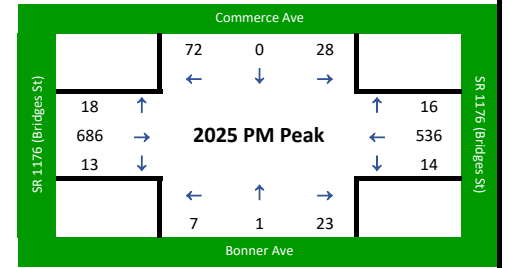
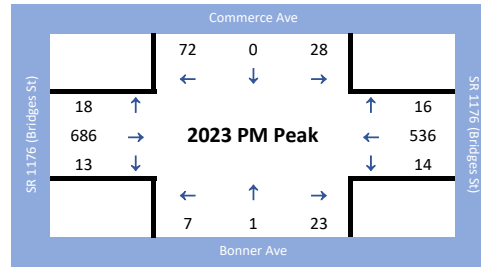
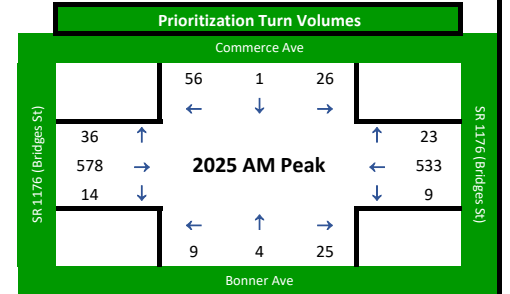
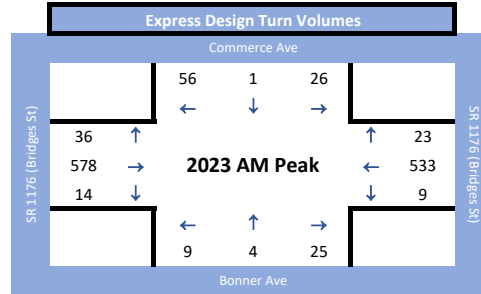
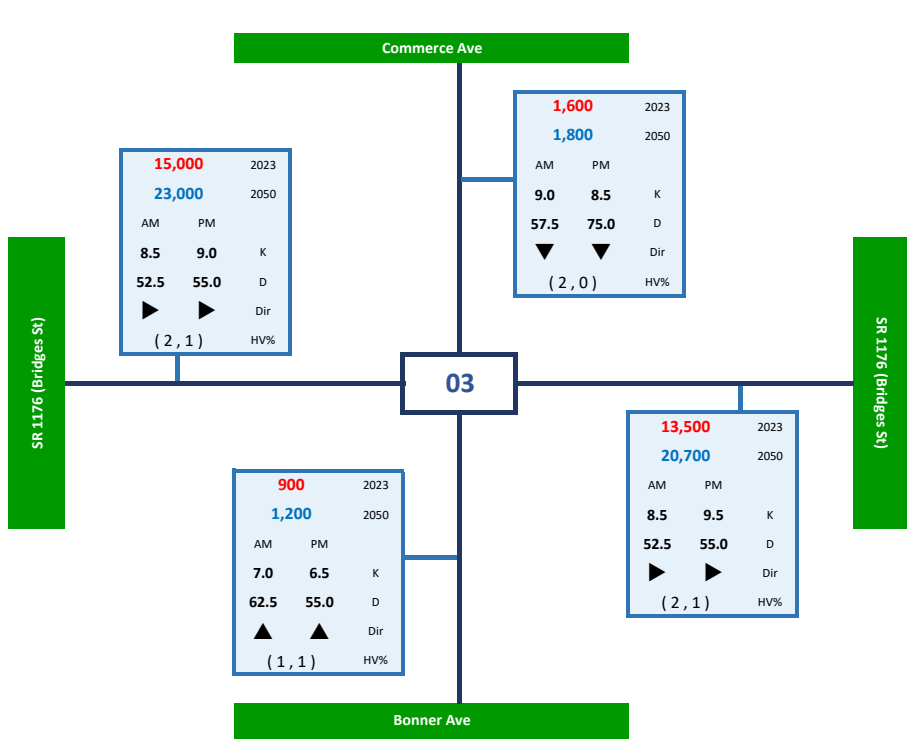

| Approach | Road Name | Route Type | No. of Lanes | Facility Type | Functional Class | Capacity | 2023 V/C Ratio |
|----------|----------------------|------------|--------------|---------------|------------------|----------|----------------|
| North | Commerce Ave | Local | 2 | Arterial | Local | 15,843 | 0.10 |
| East | SR 1176 (Bridges St) | SR | 2 | Arterial | Arterial | 15,843 | 0.85 |
| South | Bonner Ave | Local | 2 | Arterial | Local | 15,843 | 0.06 |
| West | SR 1176 (Bridges St) | SR | 2 | Arterial | Arterial | 15,843 | 0.95 |

| Approach | Road Name | Express Design Traffic Volumes | | | Prioritization Traffic Volumes | | |
|----------|----------------------|--------------------------------|----------------|-----------|--------------------------------|----------------|-----------|
| | | 2023 AADT | 2023-2050 CAGR | 2050 AADT | 2025 AADT | 2025-2035 CAGR | 2035 AADT |
| North | Commerce Ave | 1,600 | 0.5% | 1,800 | 1,600 | 1.0% | 1,800 |
| East | SR 1176 (Bridges St) | 13,500 | 1.6% | 20,700 | 13,500 | 0.4% | 14,100 |
| South | Bonner Ave | 900 | 1.2% | 1,200 | 900 | 1.0% | 1,000 |
| West | SR 1176 (Bridges St) | 15,000 | 1.6% | 23,000 | 15,000 | 0.4% | 15,700 |

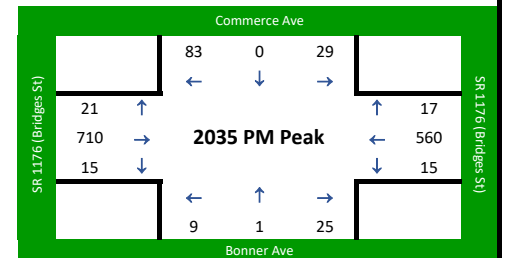
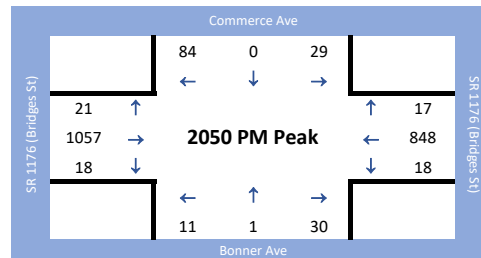

| | | | | |
|----|----------------|-----------|-----------------|---|
| -- | H250723 | 04 | Carteret | SR 1176 (Bridges St) @ SR 1749 (N 24th St)/N 24th St |
|----|----------------|-----------|-----------------|---|

STIP No. SPOT ID Int. No. County Intersection Location

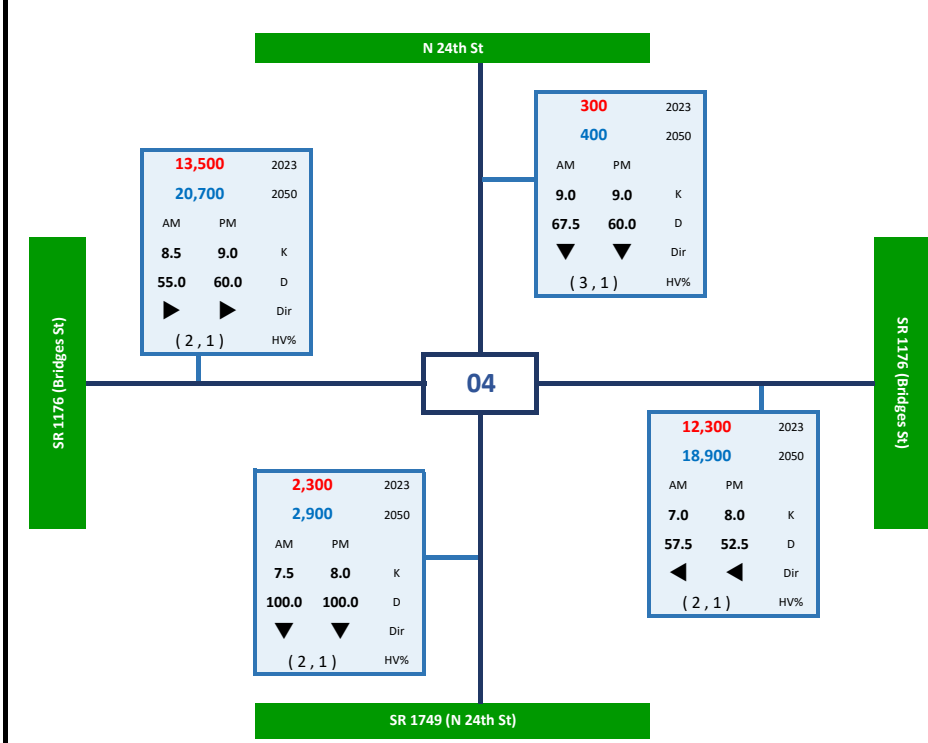

| Approach | Road Name | Route Type | No. of Lanes | Facility Type | Functional Class | Capacity | 2023 V/C Ratio |
|----------|----------------------|------------|--------------|---------------|------------------|----------|----------------|
| North | N 24th St | Local | 2 | Arterial | Local | 15,843 | 0.02 |
| East | SR 1176 (Bridges St) | SR | 2 | Arterial | Arterial | 15,843 | 0.78 |
| South | SR 1749 (N 24th St) | SR | 2 | Arterial | Local | 15,843 | 0.15 |
| West | SR 1176 (Bridges St) | SR | 2 | Arterial | Arterial | 15,843 | 0.85 |

| Approach | Road Name | Express Design Traffic Volumes | | | Prioritization Traffic Volumes | | |
|----------|----------------------|--------------------------------|----------------|-----------|--------------------------------|----------------|-----------|
| | | 2023 AADT | 2023-2050 CAGR | 2050 AADT | 2025 AADT | 2025-2035 CAGR | 2035 AADT |
| North | N 24th St | 300 | 1.0% | 400 | 300 | 1.0% | 300 |
| East | SR 1176 (Bridges St) | 12,300 | 1.6% | 18,900 | 12,300 | 0.4% | 12,800 |
| South | SR 1749 (N 24th St) | 2,300 | 0.9% | 2,900 | 2,300 | 1.0% | 2,500 |
| West | SR 1176 (Bridges St) | 13,500 | 1.6% | 20,700 | 13,500 | 0.4% | 14,100 |

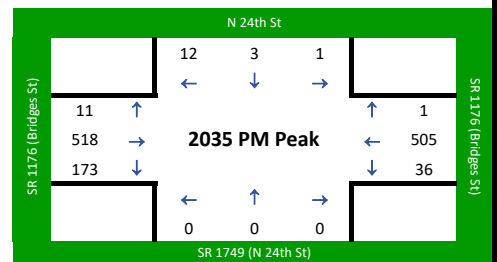
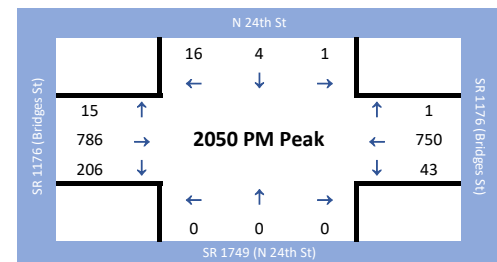
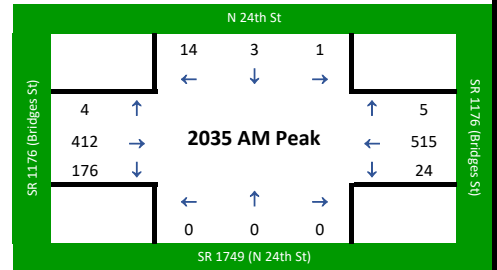
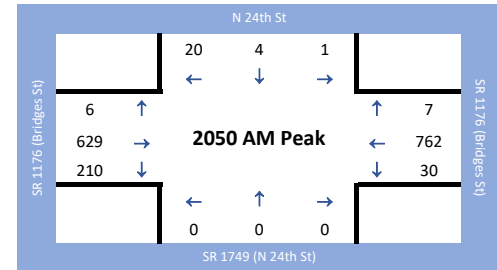
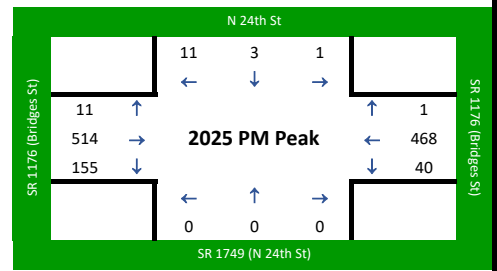
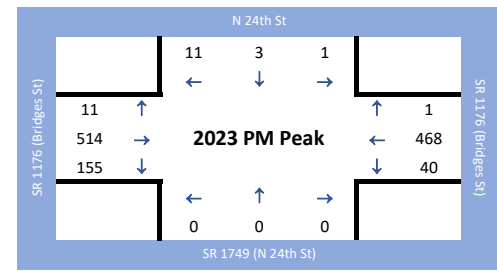
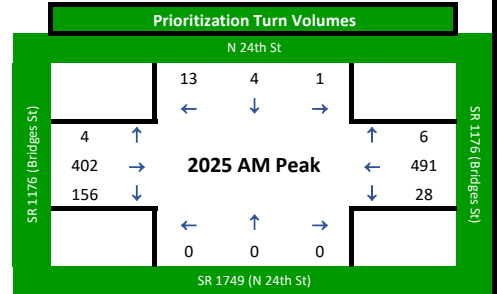
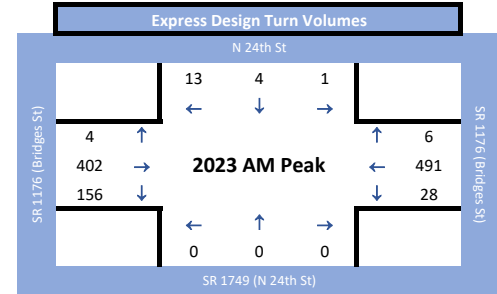

-- **H250723** **05** **Carteret** **SR 1176 (Bridges St) @ SR 1748 (N 23rd St)/N 23rd St**

STIP No. SPOT ID Int. No. County Intersection Location

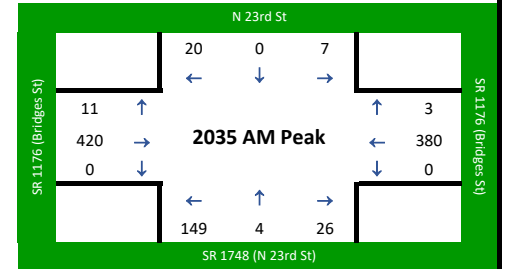
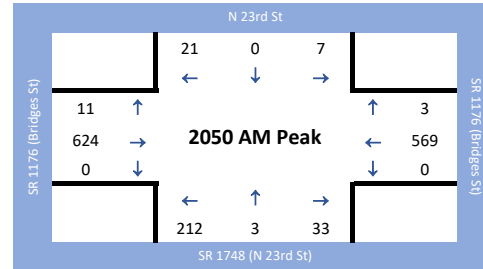
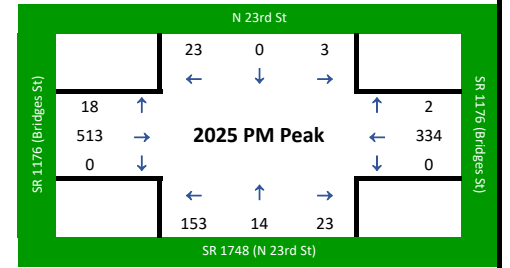
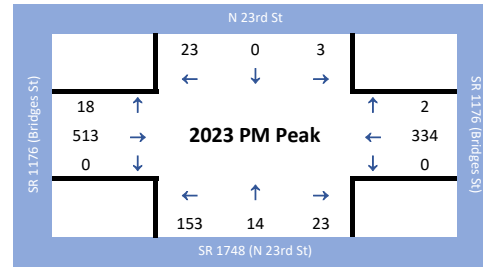
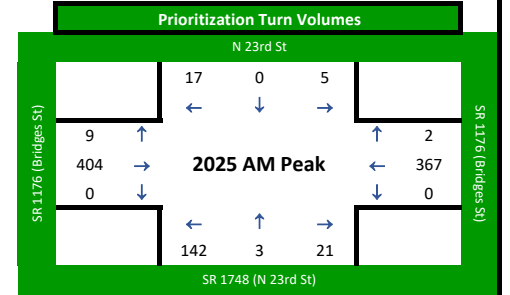
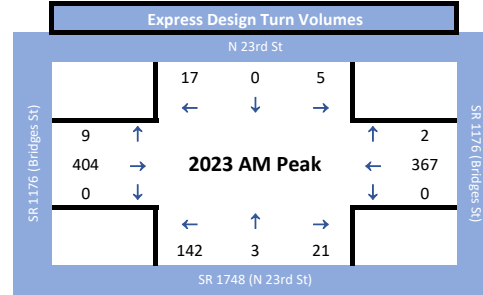
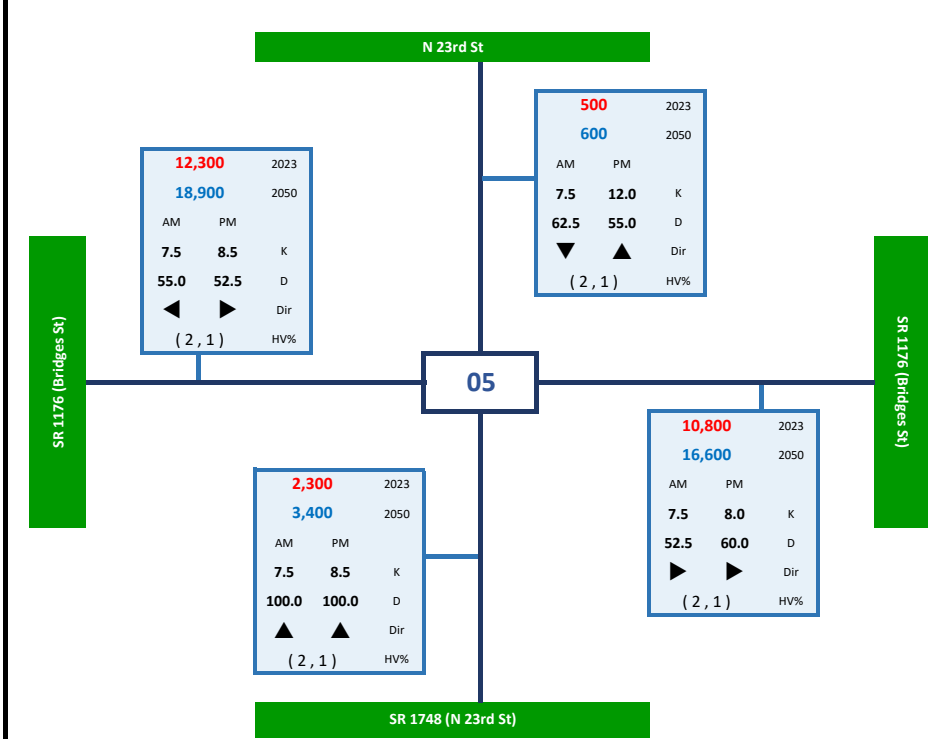

| Approach | Road Name | Route Type | No. of Lanes | Facility Type | Functional Class | Capacity | 2023 V/C Ratio |
|----------|----------------------|------------|--------------|---------------|------------------|----------|----------------|
| North | N 23rd St | Local | 2 | Arterial | Local | 15,843 | 0.03 |
| East | SR 1176 (Bridges St) | SR | 2 | Arterial | Arterial | 15,843 | 0.68 |
| South | SR 1748 (N 23rd St) | SR | 2 | Arterial | Local | 15,843 | 0.15 |
| West | SR 1176 (Bridges St) | SR | 2 | Arterial | Arterial | 15,843 | 0.78 |

| Approach | Road Name | Express Design Traffic Volumes | | | Prioritization Traffic Volumes | | |
|----------|----------------------|--------------------------------|----------------|-----------|--------------------------------|----------------|-----------|
| | | 2023 AADT | 2023-2050 CAGR | 2050 AADT | 2025 AADT | 2025-2035 CAGR | 2035 AADT |
| North | N 23rd St | 500 | 0.7% | 600 | 500 | 1.0% | 600 |
| East | SR 1176 (Bridges St) | 10,800 | 1.6% | 16,600 | 10,800 | 0.4% | 11,300 |
| South | SR 1748 (N 23rd St) | 2,300 | 1.5% | 3,400 | 2,300 | 1.0% | 2,500 |
| West | SR 1176 (Bridges St) | 12,300 | 1.6% | 18,900 | 12,300 | 0.4% | 12,800 |

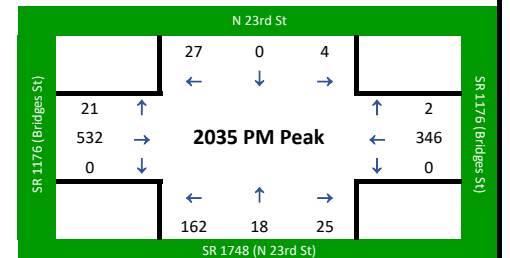
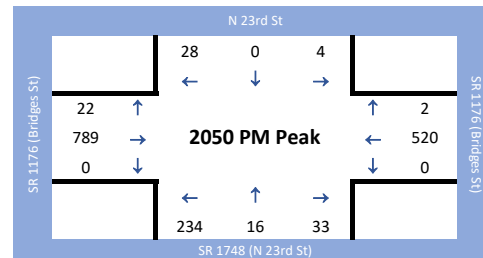

| | | | | |
|----|---------|----|----------|---|
| -- | H250723 | 06 | Carteret | SR 1176 (Bridges St)/Bridges St @ SR 1176 (N 20th St)/SR 1627 (N 20th St) |
|----|---------|----|----------|---|

STIP No. SPOT ID Int. No. County Intersection Location

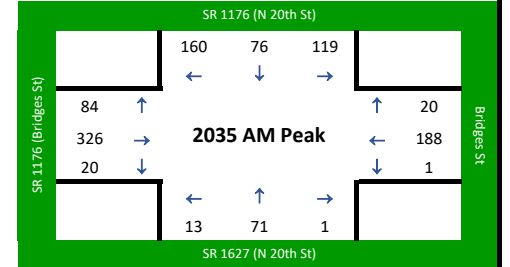
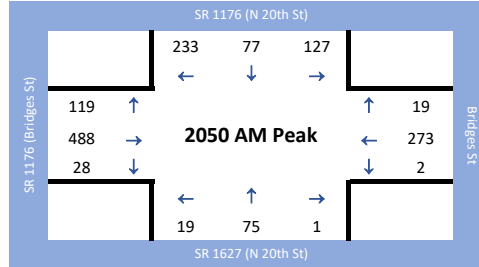
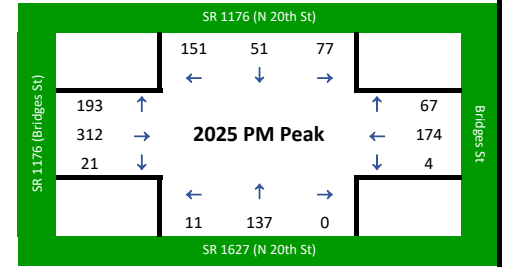
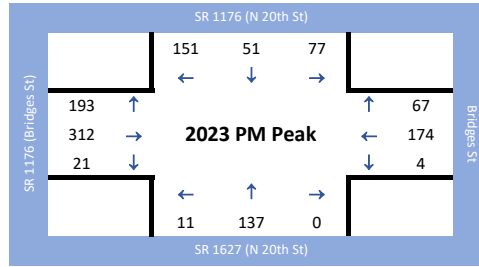
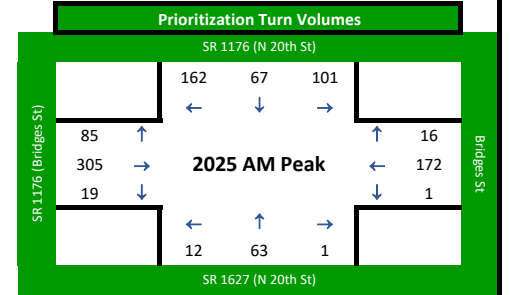
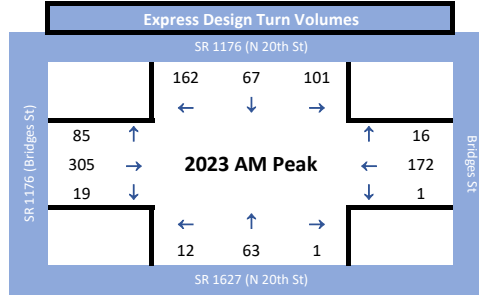
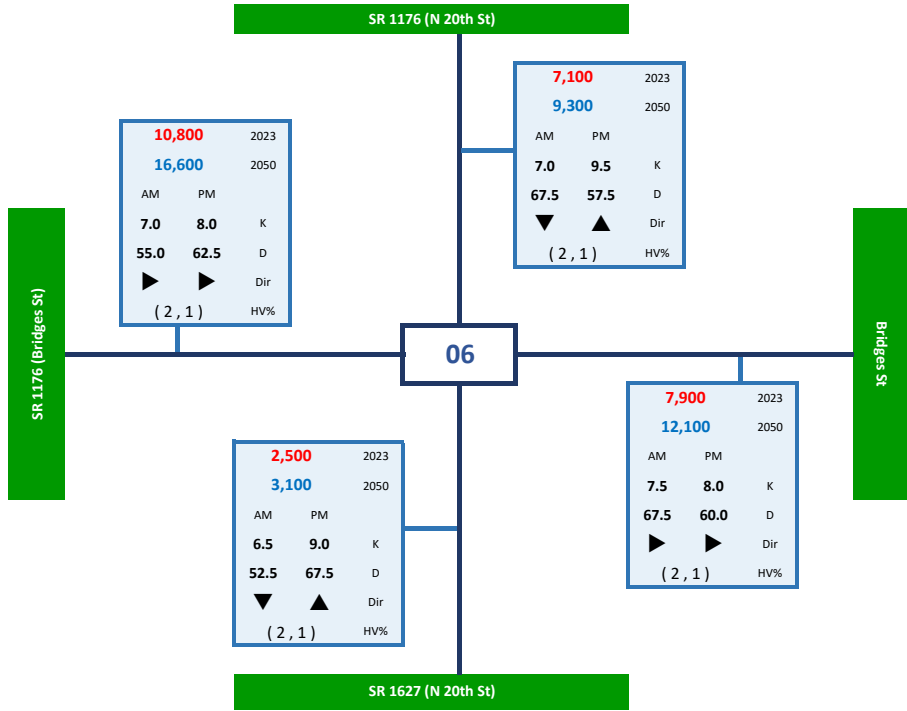

| Approach | Road Name | Route Type | No. of Lanes | Facility Type | Functional Class | Capacity | 2023 V/C Ratio |
|----------|----------------------|------------|--------------|---------------|------------------|----------|----------------|
| North | SR 1176 (N 20th St) | SR | 2 | Arterial | Arterial | 15,843 | 0.45 |
| East | Bridges St | Local | 2 | Arterial | Local | 15,843 | 0.50 |
| South | SR 1627 (N 20th St) | SR | 2 | Arterial | Arterial | 15,843 | 0.16 |
| West | SR 1176 (Bridges St) | SR | 2 | Arterial | Arterial | 15,843 | 0.68 |

| Approach | Road Name | Express Design Traffic Volumes | | | Prioritization Traffic Volumes | | |
|----------|----------------------|--------------------------------|----------------|-----------|--------------------------------|----------------|-----------|
| | | 2023 AADT | 2023-2050 CAGR | 2050 AADT | 2025 AADT | 2025-2035 CAGR | 2035 AADT |
| North | SR 1176 (N 20th St) | 7,100 | 1.0% | 9,300 | 7,100 | 0.7% | 7,600 |
| East | Bridges St | 7,900 | 1.6% | 12,100 | 7,900 | 1.0% | 8,700 |
| South | SR 1627 (N 20th St) | 2,500 | 0.8% | 3,100 | 2,500 | 1.3% | 2,800 |
| West | SR 1176 (Bridges St) | 10,800 | 1.6% | 16,600 | 10,800 | 0.4% | 11,300 |

